



Panther® HP Oil Pump Series

Model 1130-015	Panther® HP Bare Oil Pump, 3:1
Model 1130-017	Panther® HP Bare Oil Pump, 3:1, Flange Mount
Model 1130-020*	Panther® HP Bare Oil Pump, 3:1, with Bung Adapter
Model 1130-016	Panther® HP Bare Oil Pump, 5:1
Model 1130-018	Panther® HP Bare Oil Pump, 5:1, Flange Mount
Model 1130-021	Panther® HP Bare Oil Pump, 5:1, with Bung Adapter



*Model 1130-020 shown

Thoroughly read and understand this manual before installing, operating or servicing this equipment.

OPERATION, INSTALLATION, MAINTENANCE AND REPAIR GUIDE

General Safety

Thoroughly read and understand this manual before installing, operating or servicing the described products.

	<p>! IMPORTANT</p>
<p>Because this pump can be incorporated into a pressurized systems, the following safety precautions should be observed.</p> <p>Check equipment regularly and repair or replace worn and damaged parts.</p> <p>Never alter or modify any parts of this pump, doing so may cause damage to pump and/or personal injury.</p> <p>Under no circumstances should the dispensing valve be aimed at any person at any time. Personal injury may result.</p> <p>Release pressures built up in the system before any service or repair is begun. See the pressure relief procedure below.</p> <p>Do not operate this pump above 150 PSI (10.3 BAR) air inlet pressure or 200 cycles per minute.</p> <p>Always read and follow the fluid manufacturer's recommendations regarding the use of protective eye wear, clothing and respirators.</p>	

	<p>! WARNING</p>
<p>Pressure Relief Procedure:</p> <p>Follow this procedure whenever you shut off the pump, when checking or servicing any part of the system and when installing, cleaning or changing any part of the system.</p> <ol style="list-style-type: none"> 1) Disconnect the air to the pump. 2) Point dispensing valve away from yourself and others. 3) Open dispensing valve until pressure is relieved. 	

<p>! WARNING</p>
<p>If a check valve is installed at the end of the suction tube, then an external pressure relief valve must be installed at the outlet of the pump.</p>

	<p>! WARNING</p>
<p>WARNING: Panther® 3:1 pump (1130-015) develops 490 psi (34 Bar) maximum working pressure and the Panther 5:1 pump (1130-016) develops 760 psi (52.4 Bar) maximum working pressure at 150 psi (10.3 Bar) maximum inlet air pressure and stall conditions. Be sure that any components or accessories used in the system are rated to withstand this pressure. To determine fluid output pressure at stall conditions, multiply the ratio of the pump by the air pressure being used.</p> <p>EXAMPLE: 5:1 Pump Ratio x 100 psi air pressure = 500 psi fluid pressure at stall.</p>	

	<p>! WARNING</p>
<p>THIS PUMP CONTAINS ALUMINUM AND ZINC PARTS. DO NOT use 1-1-1 Trichloroethane, methylene chloride or other halogenated hydrocarbon solvents or fluids containing such solvents in this pump. Use of these solvents/fluids may result in a violent chemical reaction, causing serious bodily injury, property damage or death. All fluids used in this pump must be chemically compatible with the wetted parts materials shown on page two (2) of this manual. Consult your chemical supplier to ensure compatibility.</p>	

	<p>! WARNING</p>
<p>DANGER: Not for use with fluids that have a flash point below 100°F (38°C). Examples: gasoline, alcohol. Sparking could result in an explosion which could result in death.</p>	

	<p>! WARNING</p>
<p>In the presence of explosive vapors, take action to prevent static sparking. Failure to ground the pump, piping, valves, containers, or other miscellaneous equipment can result in fire or explosion. A green grounding lug is provided on the pump.</p>	

<p>! CALIFORNIA PROPOSITION 65</p>
<p>This product contains a chemical known to the State of California to cause cancer, birth defects or other reproductive harm. Wash hands after handling</p>

Table of Contents

Cover.....	1	Pump Repair/Serviceing.....	5-6
General Safety Information.....	2	Troubleshooting Guide	7
Product Description	3	Parts List.....	8-13
Technical Data.....	3	Parts Diagram.....	8-13
Pump Installation.....	4	Pump Dimensions	14
Preventive Maintenance	4	Accessories	15
Operation.....	5	Warranty Information	16

Product Description

The 3:1 ratio Panther® pump can service as many as three dispense points at up to 500 feet. The 5:1 ratio Panther® pump is suitable for simultaneous fluid distribution of up to two dispense points at a distance of up to 700 feet.

The Panther's air motor features a precision air reversing valve mechanism with dual valve ports for improved high speed breathing. It also contains a positive trip detent spool mechanism that eliminates stalling (blowing air) by preventing the pump from being caught between strokes. It has a simple yet durable construction with all internal parts lubricated at the factory using a life-tested synthetic grease (Balcrank P/N 826733). This grease coats all internal parts and repels air line moisture to inhibit corrosion.

The Panther® pumping assembly features a stainless pump rod for superior wear and corrosion resistance. The pump's exterior is constructed from aircraft grade extruded aluminum for an outstanding strength to weight ratio. The pump also has high quality seals and is designed for overall reliability and ease of service.

Technical Data

	Models 1130-015 1130-017	Models 1130-016 1130-018
Pressure Ratio	3:1	5:1
Air Motor, Effective Dia.	2.50"	2.50"
Stroke	3.25"	3.25"
Air Motor Displacement	30.4 in ³	30.4 in ³
Cycles per Gallon ¹	34	57
Maximum Flow Rate ¹	8.0 GPM	6.0 GPM
Operating Air Pressure Range	10-150 psi (.69-10.2 Bar)	10-150 psi (.69-10.2 Bar)
Recommend Operating Range	40-125 psi (2.8-8.6 Bar)	40-125 psi (2.8-8.6 Bar)
Air Consumption, @ 100 psi Air (4 GPM 3:1 & 3 GPM 5:1)	19.7 SCFM	24.8 SCFM
Fluid Suction Lift	20 In. Hg.	20 In. Hg.

Common Specifications:

Ports: Fluid In 1" NPTF/1-1/2" NPTM, Fluid Out 3/4" NPTF (3:1 pump) and 1/2" NPTF (5:1 pump), Air In 1/4" NPTF

Wetted Parts: Steel, Nickel Plated Steel, Stainless Steel, Aluminum, Ultrathane, Buna-N™, Nylon

Compatible Fluids: Petroleum and synthetic motor oils, gear oil, ATF, hydraulic oil

1. Free Flow @ 100 psi air.

Pump Installation



WARNING: Attach a proper ground wire to the Panther's grounding lug (item 25) before starting the pump.



CAUTION: Performance will be affected by a suction path seal that is not air tight. All threaded connections need to have Teflon™ tape or other suitable means to achieve a tight air and fluid connection.

If mounting to a reservoir bung port, thread the pump bung adapter (4411-009N) into the bung thread on the fluid reservoir, attach a suitable suction tube or hose to the pump fluid entry port, lower the pump into the mounted bung adapter, then tighten. Install the 1/8" NPT x 3/8" barb in the port on the bung adapter. Slide one of the spring clamps on to each end of the included 3/8" clear tubing. Connect one end of the tubing to the barb fitting on the pressure relief valve (15) and the other end to the barb on the bung adapter. Slide the spring clamps up on both barb fittings to secure the tubing. If mounting with a double-tapped bushing (4411-018N) attach the suction tube or hose to the double-tapped bushing, thread the bushing into the bung thread on the fluid reservoir, and attach the pump to the double tapped bushing. The suction tube should be submerged in the tank liquid and should reach to within 1 to 2 inches from the bottom of the reservoir. Install the 1/8" NPT x 3/8" barb in the port on the double tapped bushing. Slide one of the spring clamps on to each end of the included 3/8" clear tubing. Connect one end of the tubing to the barb fitting on the pressure relief valve (15) and the other end to the barb on the double tapped bushing. Slide the spring clamps up on both barb fittings to secure the tubing.



CAUTION: Always tighten pump down securely to avoid damage to the fluid reservoir, the pump, and nearby equipment. Be sure to use only the specified bung adapter.

If mounting onto a wall bracket, place the pump in the bung-mount adapter provided on the bracket,

then tighten the adapter clamping threads. Attach a wall mount Suction Assembly Kit to the pump, then lower the suction tube into the reservoir, adjusting height to set the end of the tube 1 to 2 inches above the bottom of the reservoir. The connection on the pressure relief valve (15) will need to be routed back to the reservoir or a safe collection point using 3/8" I.D. tubing of the appropriate length. The optional model 4411-024N 2" pvc fill port collar can be used on a standard 2" NPT bung port to facilitate routing the pressure relief connection back to the reservoir. Provide a drop-tee fitting, 1/4" size or larger, in the nearby air supply pipeline. From that tee, install the following pump air line assembly:

- pipe bushing or adapter (to bring the line drop size to 1/4" male)
- 1/4" pipe drop to pump level
- 1/4" pipe elbow
- 1/4"-1/2" shutoff ball valve (having an air relief vent when closed)
- 1/4"-1/2" F-R-L
- 1/4" x 3 ft. air hose
- 1/4" air line coupler and nipple.

Attach the air nipple to the air inlet port of the Panther® pump. During assembly of the air supply line, be sure to blow out all foreign materials before making connection to the pump.

Balcrank® recommends that an air line lubricator be used with turbine oil (viscosity 150-170 SSU @ 100 ° F) and set at a maximum oil feed rate of 1 drop every 2 hours of pump operation.

The pump air motor has been coated with a special synthetic grease at initial assembly (available as Balcrank P/N 826733) and does not require additional greasing except during reassembly after a repair.

Preventive Maintenance

The Panther® Pump has been designed to operate dependably with little required maintenance. However, to ensure pump longevity, the following should be observed:

- Keep the fluid free of trash and debris. Periodically check the pump inlet for foreign matter and clean when necessary.

Pump Operation



CAUTION: Always read and follow fluid manufacturers' recommendations regarding proper use of protective eye wear, clothing and respirators.



CAUTION: Read all limitations which apply to selection of fluids which may be pumped by this product. Do not pump a fluid which is not specified to be compatible.

- Run the pump at the minimum pressure required to achieve the desired flow rate (*less than 125 psi and 200 cyc/min recommended*).
- Ensure the pump receives clean, moisture free air. Check and maintain the system's air filter on a regular basis.
- Although the air motor is coated with synthetic grease upon factory assembly and can run without lubricated air, Balcrank recommends an in-line F.R.L. be installed in the pumping system.
- Never let the pump run dry of the fluid being pumped.

To Start Pump:

1. Immerse the pump's suction tube or fluid inlet into the fluid to be pumped.
2. Connect the air coupler to the pump and turn the air regulator to the minimum setting.
3. Direct pump outlet hose into an approved waste oil container.
4. Slowly adjust the air regulator until the pump is primed and running smoothly. Be sure all air has been purged from the system. The pump should prime in less than 30 seconds.
5. Use the air regulator to control the pump's speed and cycle rate. Always use the lowest pressure required to obtain the desired flow rate. This will increase pump and seal life.
6. Never allow a pump to be run dry of the fluid being pumped. A dry pump quickly speeds

Pump Repair/Service



WARNING: Before beginning pump repair, all internal pressure must be relieved. To reduce risk of personal injury, follow the **Pressure Relief Procedure** shown on pg. 2 and pg.6.

up, which could damage the air motor and fluid seals. If the pump suddenly speeds up, cut off the air supply as soon as possible and refill the reservoir with fluid and reprime the system.

7. Read and follow the instructions for each component in your system.
8. If the pump will be unattended for any period of time, or to shut off the system at the end of a work shift, *always* follow the **Pressure Relief Procedure** on page 2 of this manual.



Removing the Air Motor: Remove the 4 nuts (24) from the adapter (1). Holding lower body (23) pull up approx. 2 inches from adapter (1). Unhook the tee head on rod (11) from tee slot in coupler (48). Remove 4 carriage bolts (17) from pump. Remove insert (22) from air piston (43). While holding cap (18), pull air motor assembly from upper body (20). Reassemble in reverse order, *using grease (p/n 826733) on all seals and o-rings.*

Replacing the Air Motor Seals: Place air motor on clean work surface with the air valve mechanism up. With a straight screwdriver, remove the ball detent retainers (39) from piston (43) (ensure the balls (41) are removed). With two 7/16" wrenches, remove the two nuts (33) from the top of the intake valves (46). Now, hold center rod (26) and pull valve bar assembly from piston (43). Check for wear on all seals (19, 21, 38, 42), balls (41), and springs (30,31) and replace as required. Reassemble in reverse order, using the diagram as a guide. *Use grease (p/n 826733) on all seals and o-rings.*

Pump Repair/Service

Replacing the Pump Rod Seals: Remove foot valve (10) from fluid tube (6). Remove fluid tube (6) from adapter (1) and slide off. With a 7/16" wrench, remove the 4 nuts (24). Slide the adapter (1) down about 2 inches and unhook the rod (11) from the coupler (48). With two spanner wrenches remove fluid piston (14) from fluid rod (11). Remove the fluid rod (11) from the adapter (1). Now seals (4, 5, and 13) are accessible. Inspect balls (8) and change as required. Reassemble in reverse order. Apply grease (P/N 826733) to seals (4 and 13) to ease assembly.

Footvalve: With a strap wrench attached on the tube (6) now remove foot valve (10) with a pipe wrench. Remove and inspect pin (9) for wear, straightness, etc. Replace if required. Remove footvalve ball (8) and seal (7), inspect, and replace if required. Reassemble in reverse order.

	 WARNING
Pressure Relief Procedure:	
Follow this procedure whenever you shut off the pump, when checking or servicing any part of the system and when installing, cleaning or changing any part of the system.	
<ol style="list-style-type: none">1) Disconnect the air to the pump.2) Point dispensing valve away from yourself and others.3) Open dispensing valve until pressure is relieved.	

NOTE: The air motor is lubricated with a life-tested synthetic grease (P/N 826733) at the factory. This grease coats all parts and repels air line moisture to inhibit corrosion. It is imperative that any grease removed during maintenance be replaced afterwards. Contact your local Balcrank distributor, using the above part number, for replacement grease.

Troubleshooting Guide

NOTE: Check all other possible causes before disassembling pump.



CAUTION: Before servicing, reduce fluid supply pressure to zero.

Trouble	Probable Cause	Corrective Action
Pump does not operate	Inadequate air supply pressure or restricted air line Clogged lines, hoses, valves, etc. Damaged air motor	Increase or clear air supply ⁽¹⁾ Assure air is on and valves are open Open; clear ⁽¹⁾ Service / replace air motor
Air motor is not tripping over	Air motor seals are worn/damaged	Service / replace air motor
Air is leaking from exhaust and or seal damage, etc.	Air motor seals are worn/damaged	Service / replace air motor
Fluid is leaking from the exhaust	Fluid seal (4) is worn/damaged	Replace
Erratic pump operation	Air entering suction line Fluid level too low Air motor icing	Check for loose connections Refill, reprime or flush Run pump at lower pressure; run at lower cycles per minute; clean muffler (44)
Pump runs continuously	Empty fluid supply Blockage in pump tube or foot valve (10) Lower ball (8) is stuck in foot valve (10) Lower seal (13) is worn or damaged	Refill, reprime or flush Remove pump tube, clear blockage Replace ball and reseal foot valve Replace
Fluid output on one stroke only or continues to operate when dispensing valve is closed	Upper ball (8) is stuck in fluid piston (14) or one or both are damaged	Replace ball and reseal
Pump operates, but pump output on both strokes is low	Inadequate air supply pressure or restricted air line Closed or clogged solenoid valve, meter, dispensing valve, etc. Air inlet strainer/filter clogged	Increase air supply; increase air supply size Clear ⁽¹⁾ Clear ⁽¹⁾

(1) Follow the **Pressure Relief Procedure** and disconnect the fluid line. If the pump starts when the air is turned on again, the line, etc. is clogged.

Part Lists

Panther® 3:1 Ratio Pump Lower End Models 1130-015 and 1130-017

Item	Part Number	Description	Pump Qty	Service Kit Qty
				900020
1	833035	Adapter, Fluid	1	0
2	831544	Snap Ring, Adapter	1	1
3	831542	Wear Band, Adapter	1	1
4	831540	Polypak, Ultrathane	1	1
5	828359 ⁽¹⁾	O-Ring, Buna N, (-136)	1	1
	826676 ⁽²⁾	O-Ring, Buna N, (-033)	0	1
6	832560	Cylinder, Pump	1	0
7	826678	O-Ring, Buna N, (-133)	1	1
8	806962	Ball, Footvalve & Fluid Piston	2	0
9	829769	Pin, Stop	1	1
10	831993	Footvalve	1	0
11	831507	Rod, Displacement	1	0
12	831638	O-Ring, Buna N, (-325)	1	1
13	831361	Fluid Piston	1	0
14	826248	Wear Band, Fluid Piston	1	1
15	833052	Valve, Pressure Relief, 850 psi	1	0
16	833189	Kit, Pressure Relief Hose	1	0

Panther® 5:1 Ratio Pump Lower End Models 1130-016 and 1130-018

Item	Part Number	Description	Pump Qty	Service Kit Qty
				900021
1	831537	Adapter, Fluid (after 9/15/11)	1	0
	832017	Adapter, Fluid (before 9/15/11)	1	0
2	831543	Snap Ring, Adapter	1	1
3	831541	Wear Band, Adapter	1	1
4	831539	Polypak, Ultrathane	1	1
5	816852 ⁽³⁾	O-Ring Buna N (-131)	1	1
	830277 ⁽⁴⁾	O-Ring, Viton (2-031)	0	1
6	832567	Cylinder, Pump	1	0
7	829893	O-Ring, Buna N, (-030)	1	1
8	806962	Ball, Footvalve	1	0
	805814	Ball, Fluid Piston	1	0
9	829662	Pin, Stop	1	1
10	830109	Footvalve	1	0
11	831535	Rod, Displacement	1	0
12	800360	O-Ring, Buna N, (-23)	1	1
13	832175	Fluid Piston	1	0
14	831545	Wear Ring, Fluid Piston	1	1
15	833052	Valve, Pressure Relief, 850 psi	1	0
16	833189	Kit, Pressure Relief Hose	1	0

Models 1130-017 & 1130-018 Only

831203P	Mounting Plate (page 15)	1	0	0
831220	Snap Ring (page 15)	1	0	0
808376	Gasket (page 15)	1	0	0

(1) This O-ring used on models built before 10/13/08 and after 10/13/11

(2) This O-ring used on models built between 10/13/08 and 10/13/11 - Identified in service kit by twist tie.

(3) This O-ring used on models built before 11/10/08 and after 9/15/11

(4) This O-ring used on models built between 11/10/08 and 9/15/11 - Identified in service kit by twist tie

Exploded View

Panther® 3:1 and 5:1 Ratio Pumps

Lower End

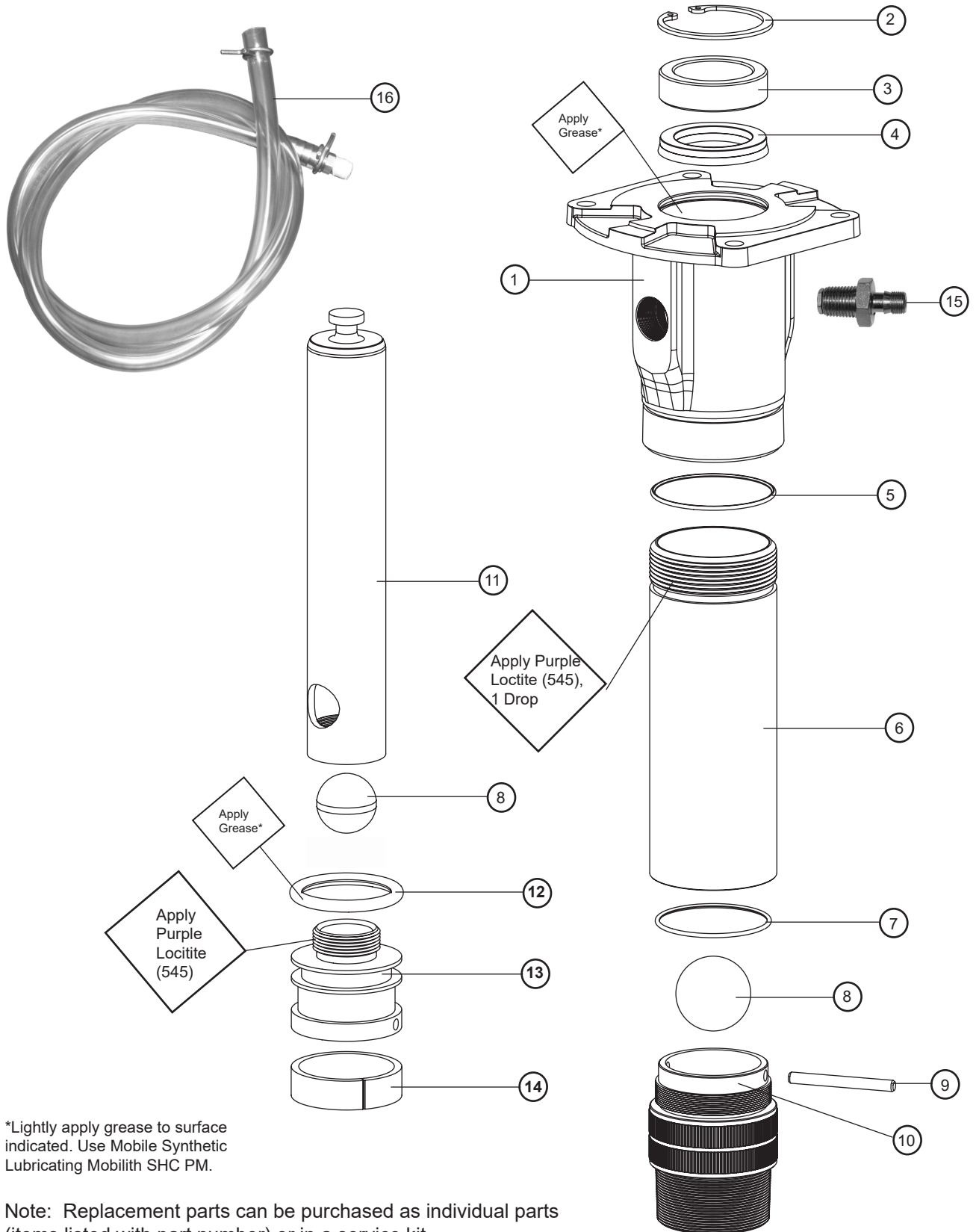

*Lightly apply grease to surface indicated. Use Mobile Synthetic Lubricating Mobilith SHC PM.

Note: Replacement parts can be purchased as individual parts (items listed with part number) or in a service kit.

Part List

Panther® Pumps Upper End All Models

Item	Part Number	Description	Pump Qty	Service Kit Qty	Service Kit Qty
				900019	900031
17	831510	Bolt, Carriage	4	0	
18	829808	Cap, Air Motor	1	0	
19	829664	O-Ring, Buna N, (-239)	2	2	2
20	832307	Upper Body, Air Motor	1	0	
21	831552	O-Ring, Buna N, (-333)	1	1	1
22	829450	Seal Insert, Air Motor	1	0	
23	832304	Lower Body, Air Motor	1	0	
24	829658	Lock Nut	4	0	
25	831489	Grounding Lug	1	0	
44	820189	Felt Muffler	1	0	

Note: Replacement parts can be purchased as individual parts (items listed with part number) or in a service kit.

Panther® HP Repair Kits

831612 - Panther® HP 3:1 FLUID complete assembly.

831613 - Panther® HP 3:1 & 5:1 AIR complete assembly.

831614 - Panther® HP Air Motor Assembly - Includes Piston.

831615 - Panther® HP 5:1 FLUID complete assembly.

900019 - Panther® HP Series pumps, air motor kit - Trip Rod Assembly.

900020 - Panther® HP 1130-015 & 1130-017 3:1 fluid seal kit.

900021 - Panther® HP 1130-016 & 1130-018 5:1 fluid seal kit.

900031 - Panther® HP Air motor kit - SOFT parts only.

Exploded View

Panther® Pumps Upper End

All Models

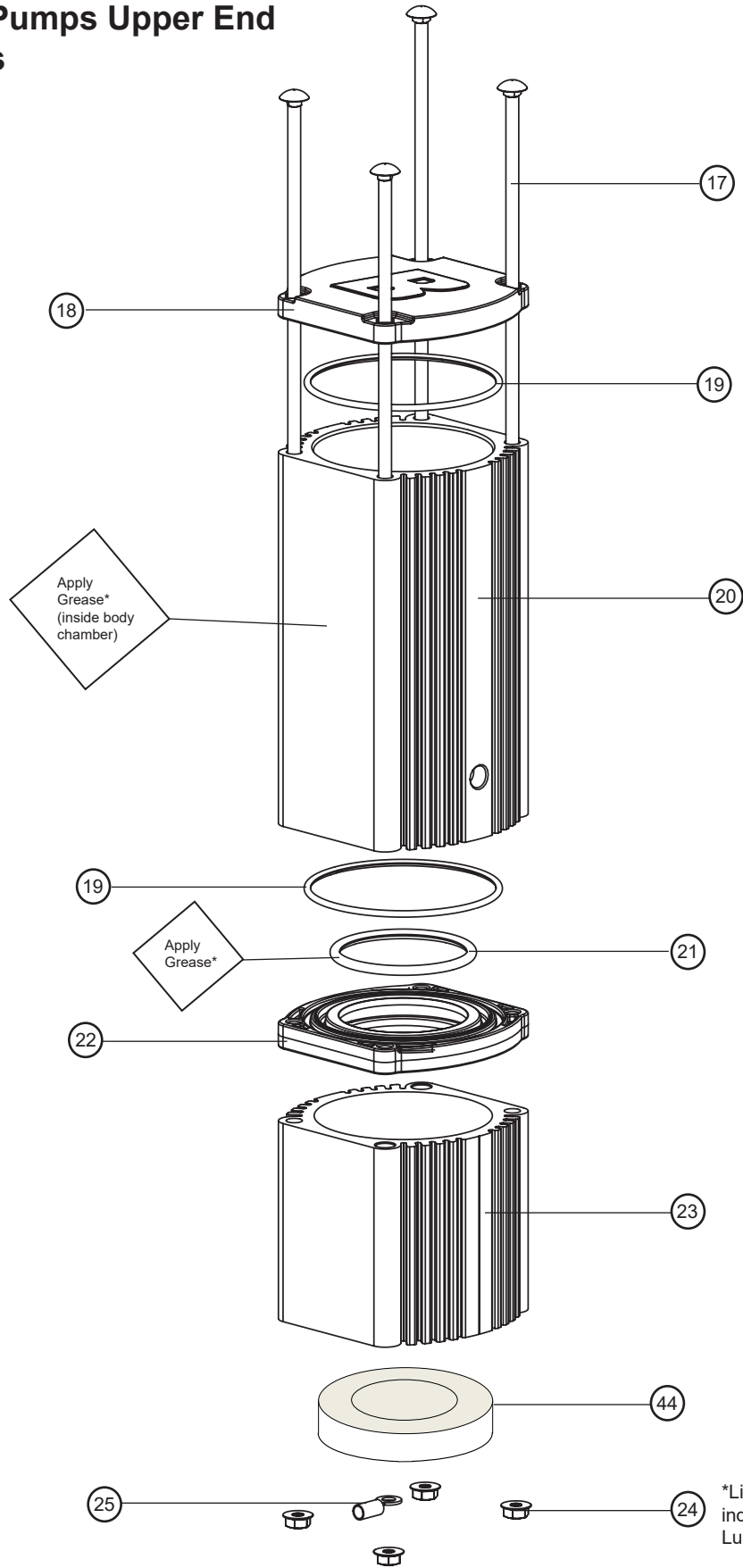

*Lightly apply grease to surface indicated. Use Mobile Synthetic Lubricating Mobilith SHC PM.

Parts List

Air Motor Panther® Series Pumps

Item	Part Number	Description	Pump Qty	Service Kit Qty	Service Kit Qty
				900019	900031
26	831779	Rod, Trip	1	1	
27		Not Used			
28	831778	Delrin, Thick Shoulder	1	1	1
29	831532	Washer	4	4	
30	830240	Spring, Inner	2	2	
31	830236	Spring, Outer	2	2	
32	830611	Retnr., Spring	2	2	2
33	808693	Nut	5	5	
34	830612	Dampner	4	4	
35	830143	Nut	1	1	
36	829441	Valve Bar	1	1	
37	830792	Valve, Exhaust	2	2	
38	831551	O-Ring, Buna N, (-008)	4	4	4
39	829461	Retnr., Detent	2	2	
40	829661	Spring, Detent	2	2	
41	805810	Ball, Detent	2	2	
42	831553	O-Ring, Buna N, (-236)	1	1	1
43	830793	Piston, Air	1	0	
45	829999	Spool, Detent	1	1	
46	830791	Valve, Intake	2	2	
47		Not used			
48	830723	Coupler, Rod	1	0	
49	819383	O-Ring, Buna N (-019)	1	1	1
50	831777	Delrin, Thin Shoulder	1	1	1

Note: Replacement parts can be purchased as individual parts (items listed with part number) or in a service kit.

Air Motor Panther® Series Pumps All Models

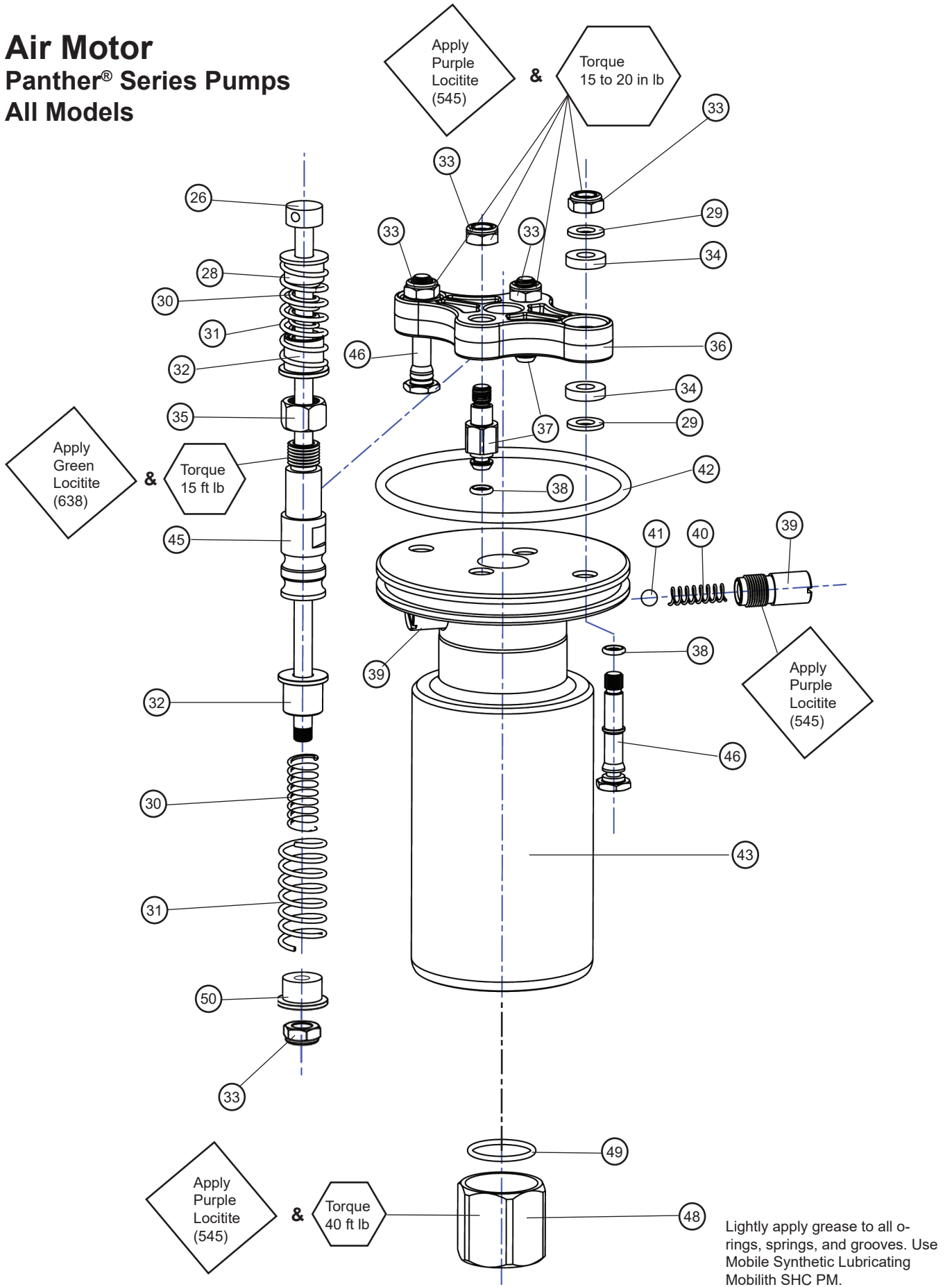

Pump Dimensions

**Flange Mount Pump
Models 1130-017 & 1130-018
with Flange Mount Kit included
with pump**

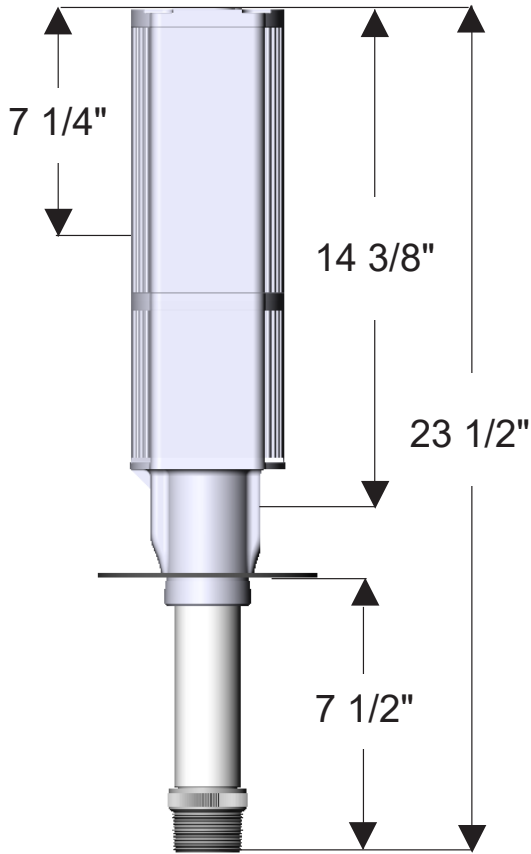

**Bare Pump Models 1130-015 & 1130-016
with optional Universal Bung Adapter
(4411-009N)**

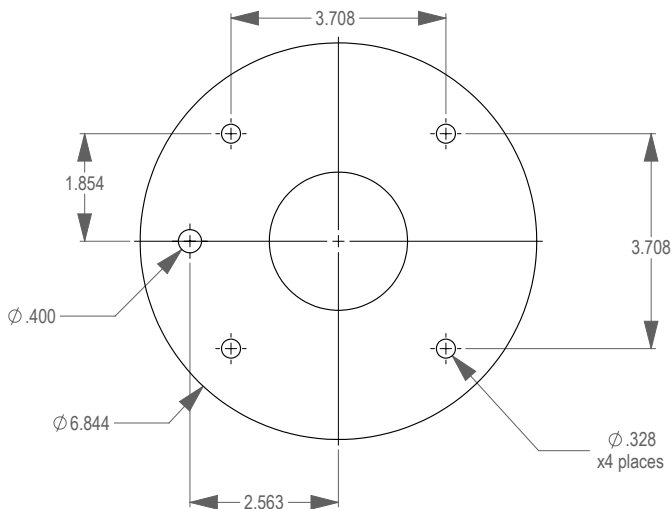
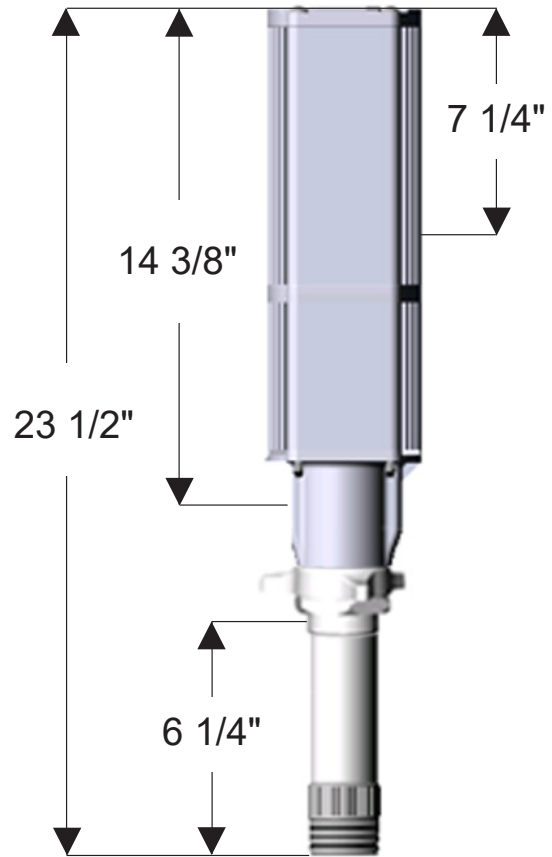

**Flange Mount Bolt Pattern
for Models 1130-017 & 1130-018
Only**

Accessories

4411-009N*
Universal Bung Adapter



4411-018N*
Double Tapped Bushing



4411-024N*
2" PVC collar for fill port



831227
Flange Mount Kit

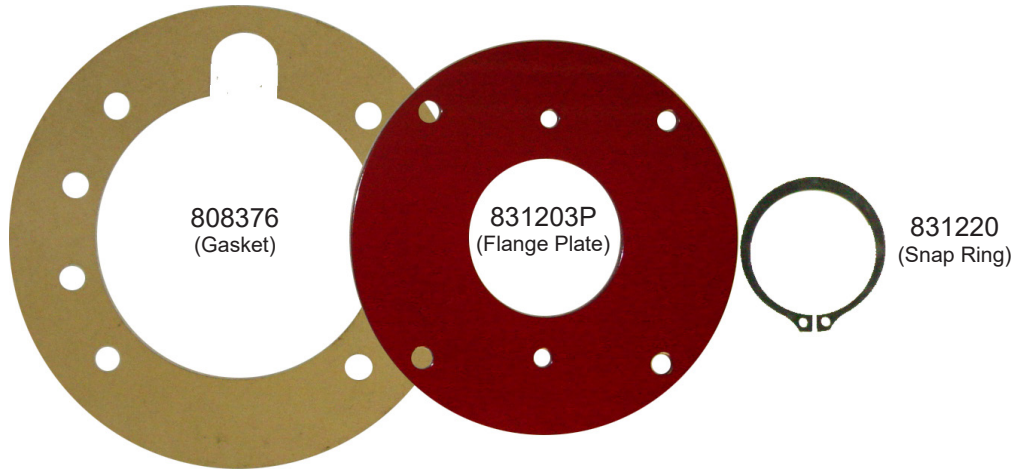

**For Warranty Information Visit:
www.balcrank.com**

Revision Log:

New Release - 6/2003
Rev. A - Changed fluid piston to 831636
Rev. B - Changed quad ring to o-ring (item 13 on 3:1)
Rev. C - Changed washer (item 50)
Rev. D - Added 831777 (item 50) and 831778 (item 28)
Rev. E - Adapter was 831538
Rev F- Changed item 5 on 1130-015 & 1130-020 & added
loctite note
Rev G - Changed item 5 on 1130-016 & 1130-021
Rev H - Changed item 14 & 10
Rev J - Changed item 1, was 831537
Rev K - Changed parts list page 8, drawing page 9, parts
list page 10.
Rev L - Changed Loctite specification on pages 9 and 13.
Rev M - Changed Item 43.
Rev N - Changed Item 22 to current part number.
Rev O - Changes items 6 on page 8. Added new O-rings
(#5) on page 8.
Rev P - Changed muffler part number (item 44) and location
of muffler for serial numbers 112410 and higher
Rev Q - Changed Item 43.
Rev R - Fluid Outlet specification for model 1130-015
changed to 1/2" NPTF
Rev S - Updated technical data. Also fluid outlet spec for
model 1130-015 changed to 3/4"
Rev T - Changed part number for item 5 (models 1130-015
and 1130-017) on page 8 and changed part numbers for
items 1 & 5 (models 1130-016 and 1130-018) on page 8
Rev U - Added part numbers for new pressure relief and
accessories
Rev V - Added flange mount bolt pattern to page 14
Rev W - Updated part number for Mounting Flange/Plate
(pages 8 & 15)
Rev X - Added California Proposition 65 to Warnings

Balcrank® Corporation
Weaverville, NC 28787
800-747-5300
800-763-0840 Fax
www.balcrank.com

Service Bulletin SB 1064
Rev. W 12/15